

Section II.

TM 9-2320-272-24P-1

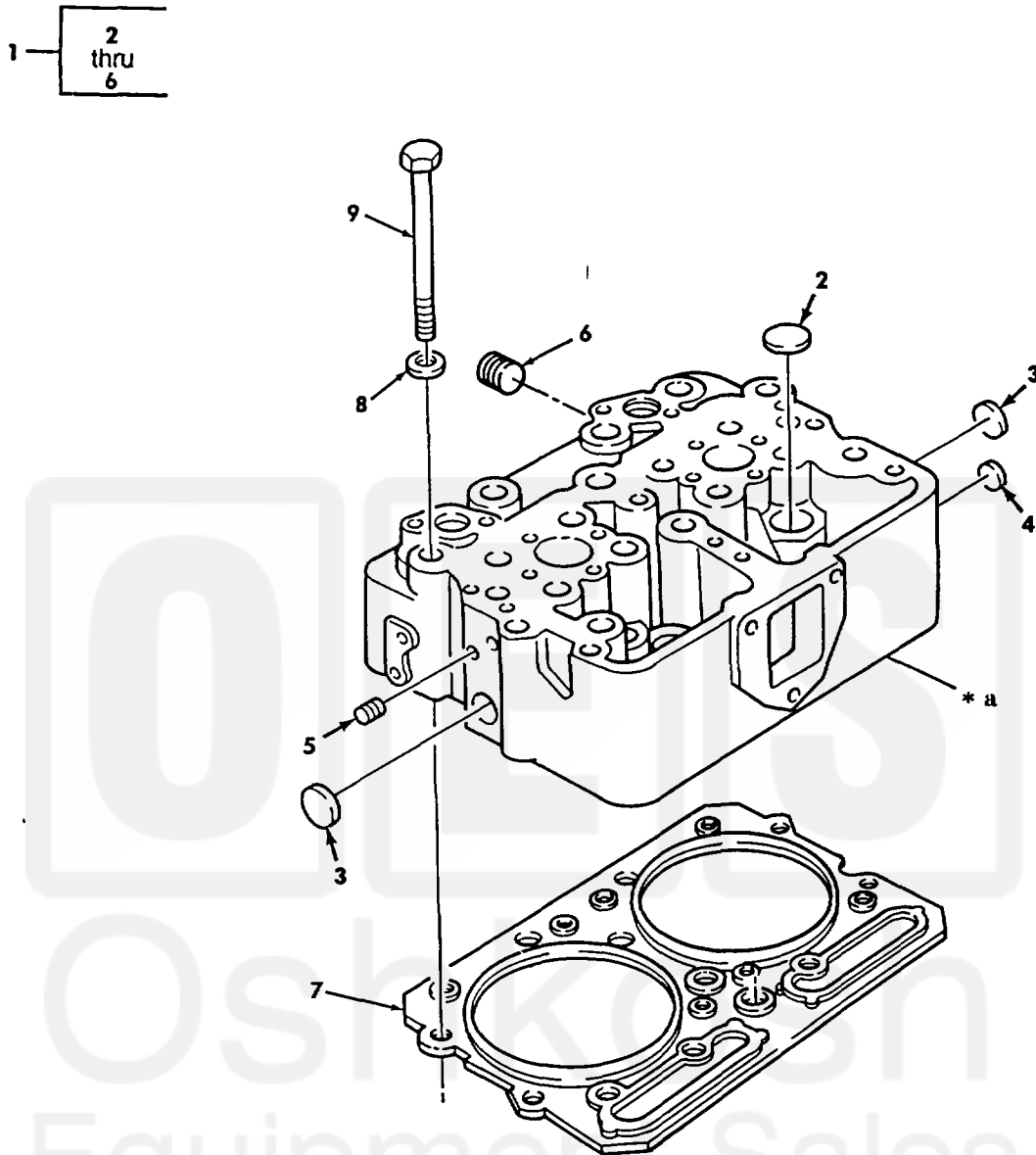

\* a PART OF ITEM 1

Figure 9. Cylinder Head Assembly, Gasket, and Mounting Hardware (M939, M939A1).

SECTION II					TM 9-2320-272-24P-1	
(1)	(2)	(3)	(4)	(5)	(6)	(7)
ITEM NO	SMR CODE	NSN	CAGEC	PART NUMBER	DESCRIPTION AND USABLE ON CODES (UOC)	QTY
					GROUP 0101 CRANKCASE, BLOCK, CYLINDER HEAD	
					FIG. 9 CYLINDER HEAD ASSEMBLY, GASKET, AND MOUNTING HARDWARE (M939, M939A1)	
1	PFFFF	2815011464182	15434	3007835	CYLINDER HEAD, DIESE ..... UOC:DAA,DAB,DAC,DAD,DAE,DAF,DAG,DAH,DAJ,DAK,DAL,DAW,DAX,V12,V13,V14,V15,V16,V17,V18,V19,V20,V21,V22,V24,V25,V39	3
2	PAFZZ	5340010870681	15434	213395	.PLUG, EXPANSION ..... UOC:DAA,DAB,DAC,DAD,DAE,DAF,DAG,DAH,DAJ,DAK,DAL,DAW,DAX,V12,V13,V14,V15,V16,V17,V18,V19,V20,V21,V22,V24,V25,V39	6
3	PAFZZ	5340010866193	15434	216524	.PLUG, EXPANSION ..... UOC:DAA,DAB,DAC,DAD,DAE,DAF,DAG,DAH,DAJ,DAK,DAL,DAW,DAX,V12,V13,V14,V15,V16,V17,V18,V19,V20,V21,V22,V24,V25,V39	2
4	PAFZZ	5340010870682	15434	213394	.PLUG, EXPANSION ..... UOC:DAA,DAB,DAC,DAD,DAE,DAF,DAG,DAH,DAJ,DAK,DAL,DAW,DAX,V12,V13,V14,V15,V16,V17,V18,V19,V20,V21,V22,V24,V25,V39	1
5	PAFZZ	4730000189566	24617	G1251	.PLUG, PIPE ..... UOC:DAA,DAB,DAC,DAD,DAE,DAF,DAG,DAH,DAJ,DAK,DAL,DAW,DAX,V12,V13,V14,V15,V16,V17,V18,V19,V20,V21,V22,V24,V25,V39	10
6	PAFZZ	4730000444715	15434	S962	.PLUG, PIPE ..... UOC:DAA,DAB,DAC,DAD,DAE,DAF,DAG,DAH,DAJ,DAK,DAL,DAW,DAX,V12,V13,V14,V15,V16,V17,V18,V19,V20,V21,V22,V24,V25,V39	4
7	PAFZZ	5330010805021	15434	3076189	GASKET ..... UOC:DAA,DAB,DAC,DAD,DAE,DAF,DAG,DAH,DAJ,DAK,DAL,DAW,DAX,V12,V13,V14,V15,V16,V17,V18,V19,V20,V21,V22,V24,V25,V39	1
8	PAFZZ	5310002858833	17576	538174	WASHER, FLAT ..... UOC:DAA,DAB,DAC,DAD,DAE,DAF,DAG,DAH,DAJ,DAK,DAL,DAW,DAX,V12,V13,V14,V15,V16,V17,V18,V19,V20,V21,V22,V24,V25,V39	36
9	PAFZZ	5305010724270	15434	177734	SCREW ..... UOC:DAA,DAB,DAC,DAD,DAE,DAF,DAG,DAH,DAJ,DAK,DAL,DAW,DAX,V12,V13,V14,V15,V16,V17,V18,V19,V20,V21,V22,V24,V25,V39	36

END OF FIGURE